

Installation Instructions

Prior to installation of the **P-LOK™ SYSTEM** on a truck or trailer bed, you must make sure that the **P-LOK™ SYSTEM** is correctly and safely positioned and that the mounting surface is stable. The following positioning parameters must be determined to assure proper and safe positioning:

Important Positioning Parameters:

- Determine the size, length, and weight of the motorcycle to be secured by the **P-LOK™ SYSTEM**.
- Determine from your truck or trailer manuals the acceptable weight limits and weight distribution requirements.
- Locate the gas/storage tanks, brake/water/electrical lines, or other mechanical truck or trailer parts that you might damage when installing the **P-LOK™ SYSTEM** (See figure 4).

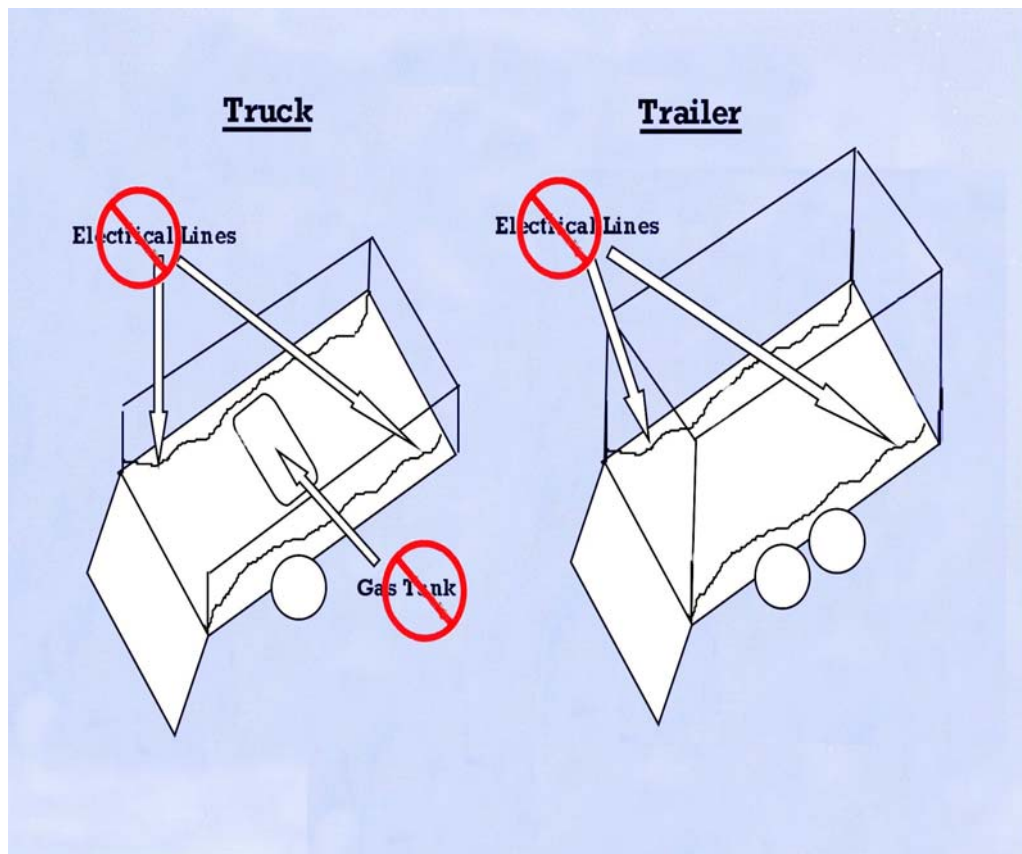

Figure 4: Typical Hazard Items/ Locations

Step 1: Determine the safe installation zones consistent with the “Important Positioning Parameters” (see figure 5):

- Allow enough space to accommodate the size, length, and weight of the motorcycle to be locked down.
- Distribute the motorcycle’s weight over the truck or trailer bed as required.
- **USE EXTREME CAUTION** when drilling through the truck or trailer bed where gas/storage tanks, brake/water/electrical lines, or other mechanical truck or trailer parts exist.

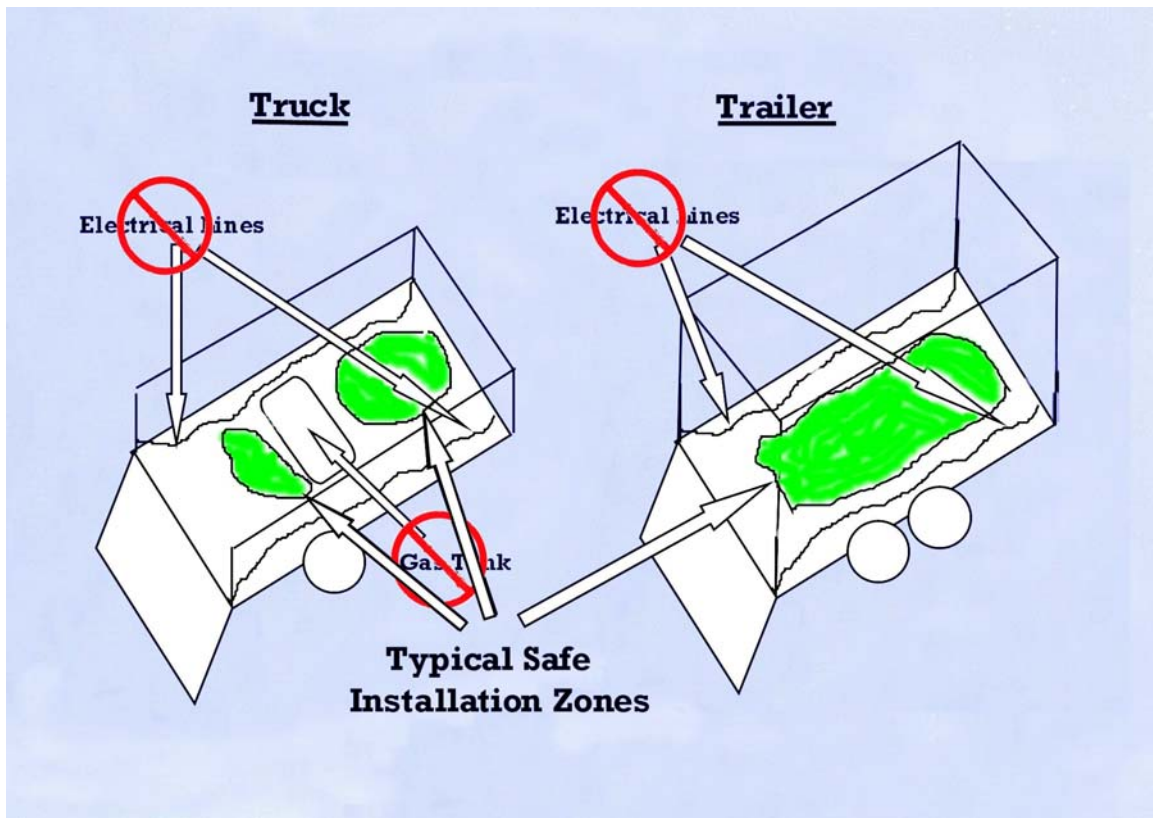

Figure 5: Typical Safe Installation Zones

Step 2: Place the **P-LOK™** Track in a safe installation position within the safe installation zones.

Step 3: With the **P-LOK™** Track positioned in a safe installation position and flat on the truck or trailer bed, mark the four track mounting holes to be drilled (see figure 6).

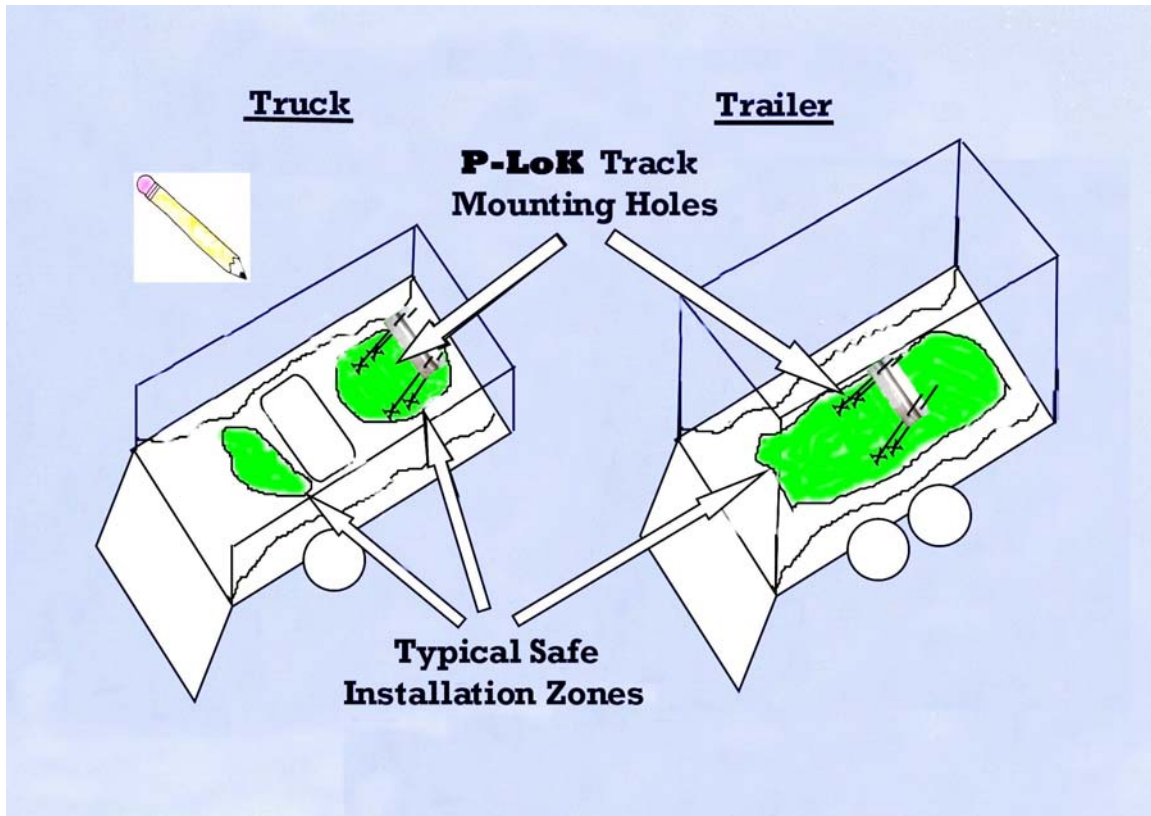

Figure 6: **P-LOK™** Track Mounting Holes (Marked)

Step 4: Remove the **P-LOK™** Track and drill the four track mounting holes using a 3/8” drill bit.

Important: A final check of the selected position consistent with the “Important Positioning Parameters” should be made prior to this step

Note: The four track mounting bolts (3/8” x 11 stainless steel bolts) supplied are 2” in length and may not be long enough for all applications.

Step 5: Replace the **P-LOK™** Track and secure it to the truck or trailer bed using the four 3/8" x 11 track bolts and the four 3/8"-16 track lock nuts (figure 7).

Note: In some applications, additional spacers (not included) along with the supplied two track bottom plates may be needed to level the corrugated truck or trailer bed for mounting the **P-LOK™** Track.

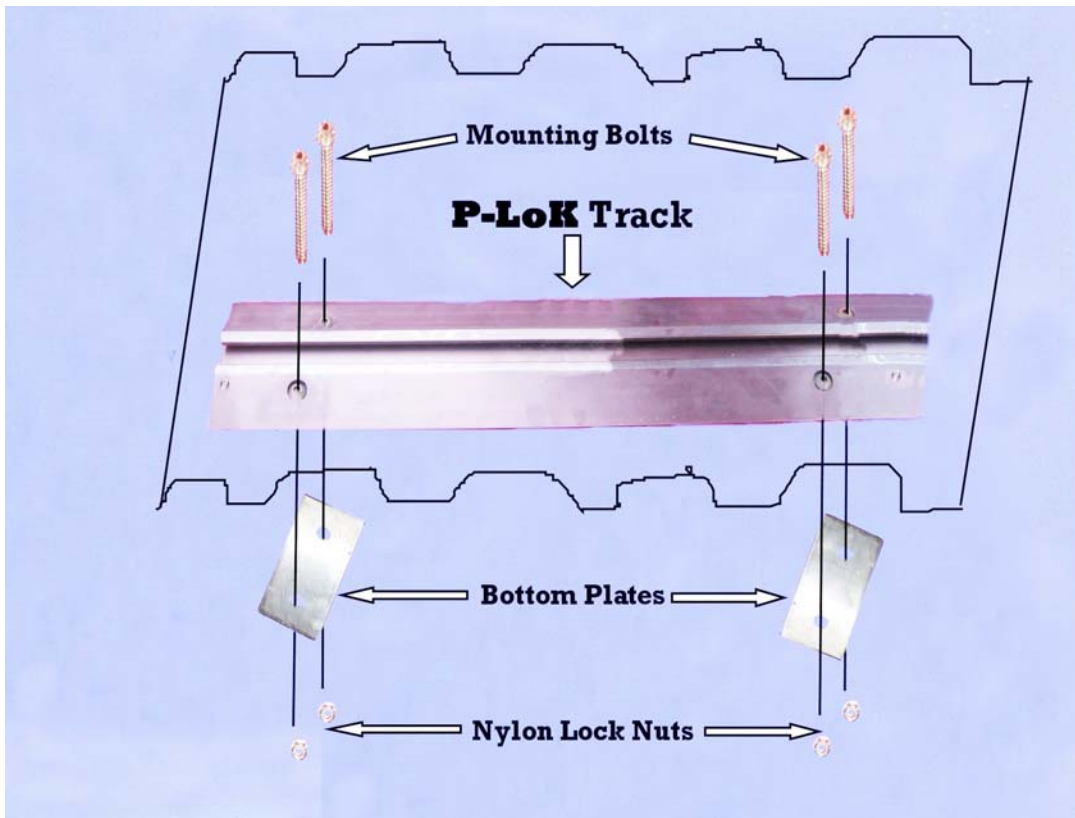

Figure 7: P-LOK™ Track Installation

CONGRATULATIONS YOUR P-LOK™ SYSTEM IS INSTALLED AND READY FOR USE. ENJOY!!!